

<b>MUSSD</b>	<b>Metrological Tests Sample Acceptance/ Rejection Form: Dipping Measures (Karandi)</b>	Date of Issue:	Doc No:
		2023-01-01	LB/PA/VL/F2.2
		Rev No: 1	Page 4 of 4

## Annex

### Specifications of Dipping Measures

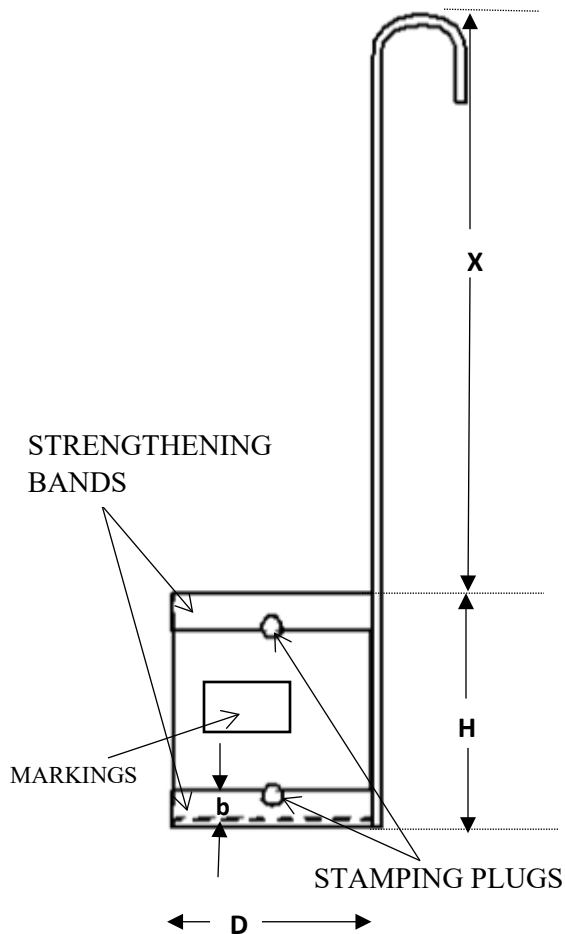

Figure 1 : Dimensions of dipping measures

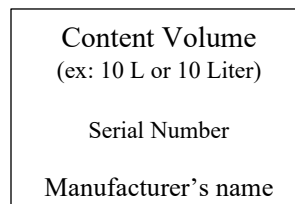

Figure 2 : Markings of dipping measures

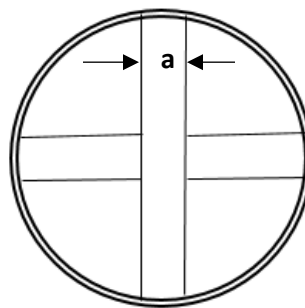

Figure 3 : Dimensions of dipping measures



Figure 4 : Dipping Measure

#### Key

Denomination	Diameter D	Height H	Length of the Handle X	a	b	Sheet Gauge
200 ml	63 mm	63 mm	≤ 186 mm	≥ 6mm	≤ 12mm	0.47 mm to 0.7 mm (S. W. G. 28 to 24)
100 ml	50 mm	50 mm	≤ 100 mm	≥ 6mm	≤ 12mm	0.47 mm to 0.7 mm (S. W. G. 28 to 24)
50 ml	40 mm	40 mm	≤ 80 mm	≥ 6mm	≤ 12mm	0.47 mm to 0.7 mm (S. W. G. 28 to 24)

Note: Tolerance on dimensions : ± 10 % or ±5 mm whichever is higher

Prepared by: TM/DTM

Reviewed by: QM/DQM

Approved by: Director